

SPECIFICATION

OF PRODUCTS

CUSTOMER : INCOMP HK

PRODUCT NAME: SMD Ceramic Resonator

PART NUMBER: 117-ZTTCC8.00MGF

Approved by	Checked by	Drawn by

Part Number Sheet	
Customer	
Supplier P/N	117-ZTTCC8.00MGF
Customer P/N	

Customer's Approval Certificate	
Checked & Approval by	
Date	

Mark Of Modification	Reason Of Modification	Modification	Drawn	Checked	Approval	Date

1. SCOPE

This specification shall cover the characteristics of the ceramic resonator with the type 117-ZTTCC8.00MGF

2. PART NO.

PART NUMBER	PREVIOUS PART NUMBER
117-ZTTCC8.00MGF	
CUSTOMER PART NO	SPECIFICATION NO

3. OUTLINE DIMENSIONS AND MARK

3.1 Appearance: No visible damage and dirt.

3.2 Construction: SMD ceramic packaging.

3.3 The products conform to the RoHS directive and national environment protection law.

3.4 Dimensions and mark

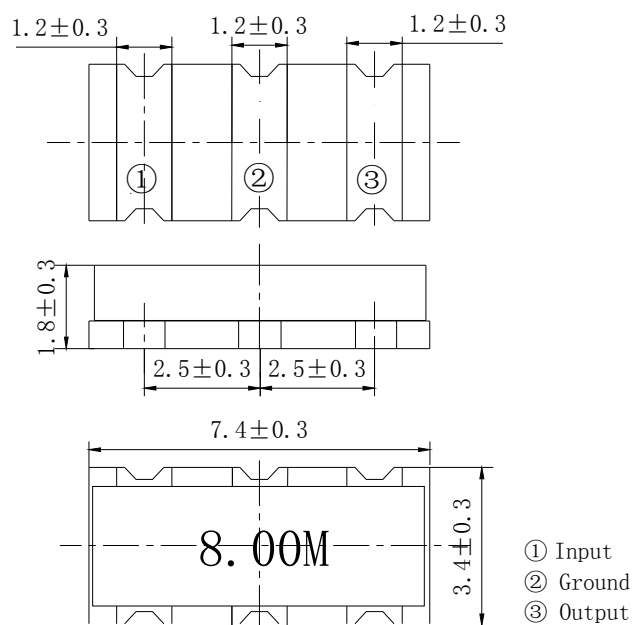

4. ELECTRICAL SPECIFICATIONS

4.1 RATING

Items	Requirement
Withstanding Voltage (V)	50 (DC, 1min)
Insulation Resistance R_i , ($M\Omega$) min.	100 (10V, 1min)
Operating temperature	-25°C ~ +85°C
Storage temperature	-55°C ~ +85°C
Rating Voltage UR (V)	6V DC
	15V p-p

4.2 ELECTRICAL SPECIFICATIONS

Items	Requirement
Oscillation Frequency f_{osc} (MHz)	8.000
Frequency Accuracy (%)	± 0.5
Resonant Impedance R_o (Ω) max.	30
Temperature Coefficient of Oscillation Frequency (%) max.	± 0.3 (Oscillation Frequency drift, -25°C ~ +85°C)
Aging Rate (%) max.	± 0.3 (For Ten Years)

5. TEST

5.1 Test Conditions

Parts shall be tested under the condition (Temp.: $20 \pm 15^\circ\text{C}$, Humidity : $65 \pm 20\%$ R.H.) unless the standard condition (Temp.: $25 \pm 3^\circ\text{C}$, Humidity : $65 \pm 10\%$ R.H.) is regulated to measure.

5.2 Test Circuit

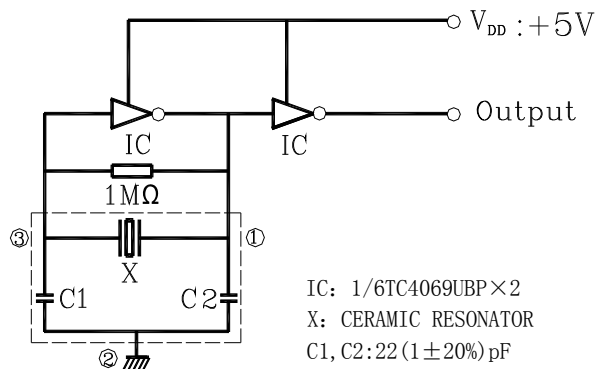

6 PHYSICAL AND ENVIRONMENTAL CHARACTERISTICS

No	Item	Condition of Test	Performance Requirements	
6.1	Humidity	Keep the resonator at $40^{\circ}\text{C}\pm 2^{\circ}\text{C}$ and 90%-95% RH for 96h. Then Release the resonator into the room Condition for 1h prior to the Measurement.	It shall fulfill the specifications in Table 1.	
6.2	High Temperature Exposure	Subject the resonator to $85^{\circ}\text{C}\pm 2^{\circ}\text{C}$ for 96h, then release the resonator into the room conditions for 1h prior to the measurement.	It shall fulfill the specifications in Table 1.	
6.3	Low Temperature Exposure	Subject the resonator to $-25^{\circ}\text{C}\pm 2^{\circ}\text{C}$ for 96h, then release the resonator into the room conditions for 1h prior to the measurement.	It shall fulfill the specifications in Table 1.	
6.4	Temperature Cycling	After temperature cycling of blow table was performed 5 times, resonator shall be measured after being placed in natural conditions for 1h.	It shall fulfill the specifications in Table 1.	
		Temperature		Time
		$-25 \pm 3^{\circ}\text{C}$		30 ± 3 min
		$85 \pm 3^{\circ}\text{C}$	30 ± 3 min	
6.5	Vibration	Subject the resonator to vibration for 2h each in x、 y and z axis With the amplitude of 1.5mm, the frequency shall be varied uniformly between the limits of 10 Hz—55Hz.	It shall fulfill the specifications in Table 1.	
6.6	Mechanical Shock	Drop the resonator randomly onto a wooden floor from the height of 100cm 3 times.	It shall fulfill the specifications in Table 1.	
6.7	Soldering Test	Passed through the re-flow oven under the following condition and left at room temperature for 1h before measurement.	It shall fulfill the specifications in Table 1.	

(To be continued)

6 PHYSICAL AND ENVIRONMENTAL CHARACTERISTICS

No	Item	Condition of Test	Performance Requirements
6.8	Solder Ability	Dipped in $245\text{ }^{\circ}\text{C} \pm 5\text{ }^{\circ}\text{C}$ solder bath for $3\text{s} \pm 0.5\text{ s}$ with rosin flux (25wt% ethanol solution.)	The terminals shall be at least 95% covered by solder.
6.9	Board Bending	<p>Mount a glass-epoxy board (Width=40mm,thickness=1.6mm),then bend it to 1mm displacement and keep it for 5s. (See the following figure)</p> 	Mechanical damage such as breaks shall not occur.

Table 1

Item	Specification after test
Oscillation Frequency Change $\Delta F_{osc}/F_{osc}$ (%) max	± 0.3
Resonant Impedance (Ω) max	35
The limits in the above table are referenced to the initial measurements.	

7 RECOMMENDED LAND PATTERN AND REFLOW SOLDERING STANDARD CONDITIONS

7.1 Recommended land pattern

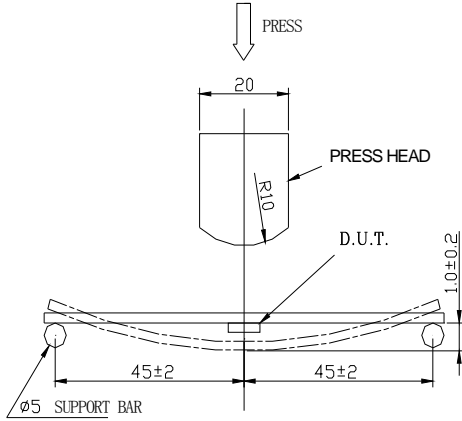
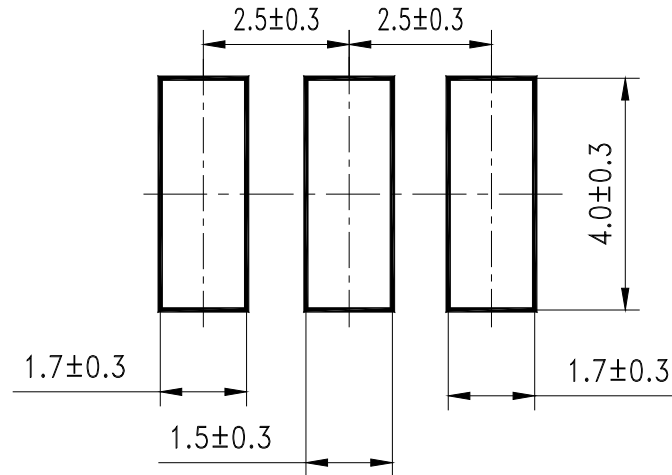

7.2 Recommended reflow soldering standard conditions

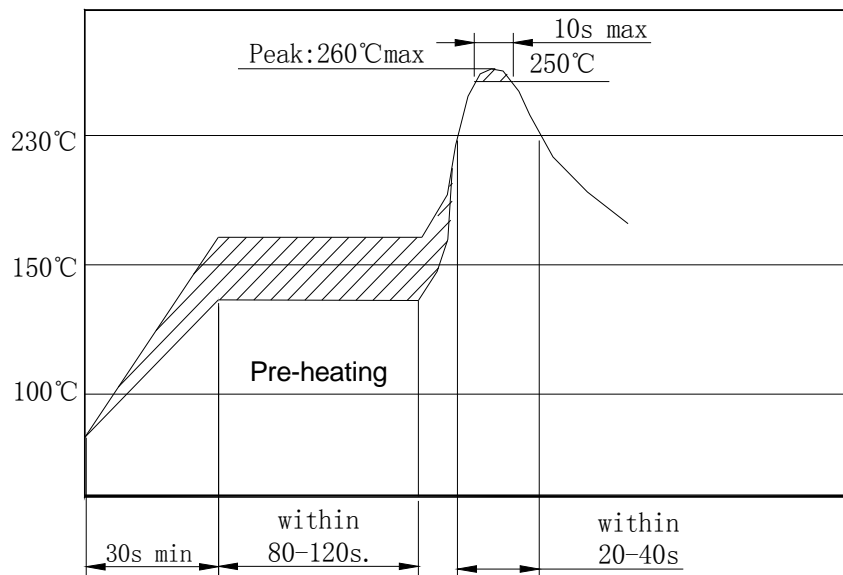

8. PACKAGE

To protect the products in storage and transportation, it is necessary to pack them (outer and inner package) .

8.1 On paper pack, the following requirements are requested.

8.1.1 Dimensions and Mark

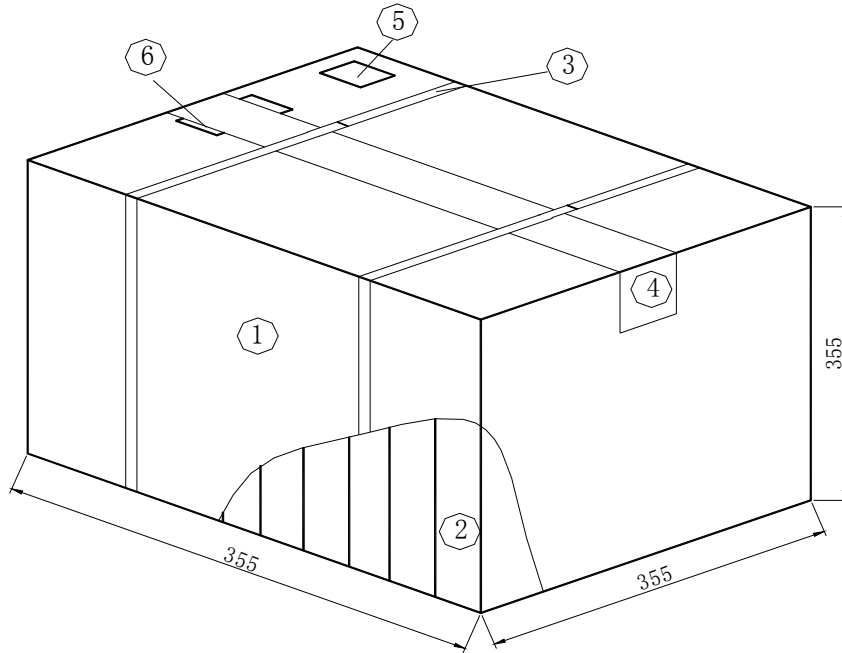

NO.	Name	Quantity
①	Package	1
②	Inner Box	12
③	Belt	2.9 m
④	Adhesive tape	1.2 m
⑤	Label	1
⑥	Certificate of approval	1

8.1.2 Section of package

Package is made of corrugated paper with thickness of 0.8cm. Package has 10 inner boxes, each box has 1 reel (each reel for plastic bag)

8.1.3 Quantity of package

Per plastic reel 4000 pieces of piezoelectric ceramic part
 Per inner box 1 reel
 Per package 10 inner boxes
 (40000 pieces of piezoelectric ceramic part)

8.1.4 Inner Box Dimensions

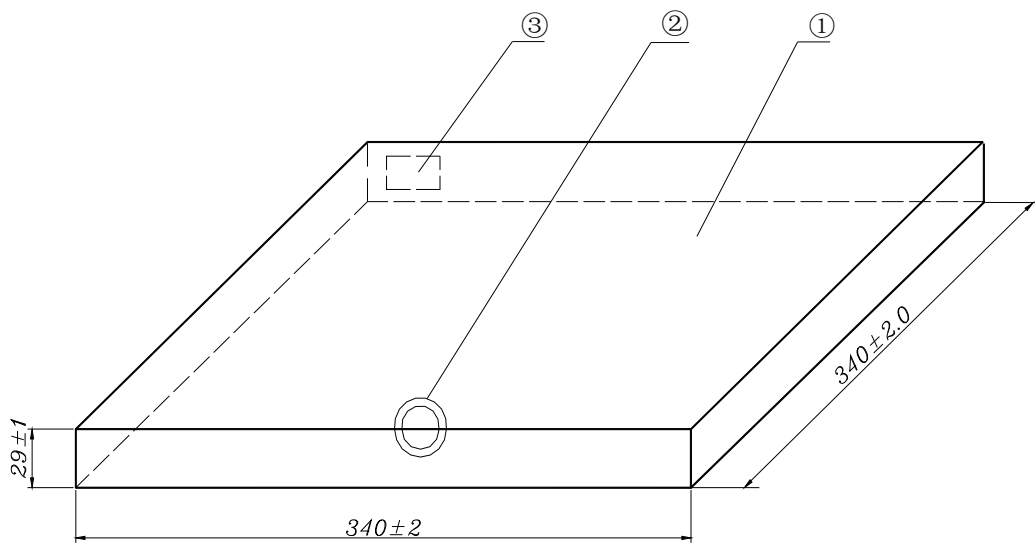

NO.	Name	Quantity
①	Inner Box	1
②	QC Label	1
③	Label	1

8.2 On reel pack, the following requirements are requested.

8.2.1 Reel Dimensions

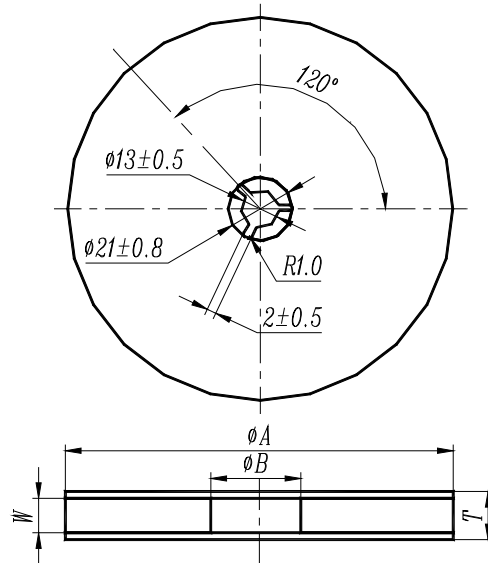

ϕA	ϕB	W	T	Pieces per reel	Carrier tape size
330 ± 3	80min	16.4min	22.4max	4000typ.	16

8.2.3 Packing Method Sketch Map

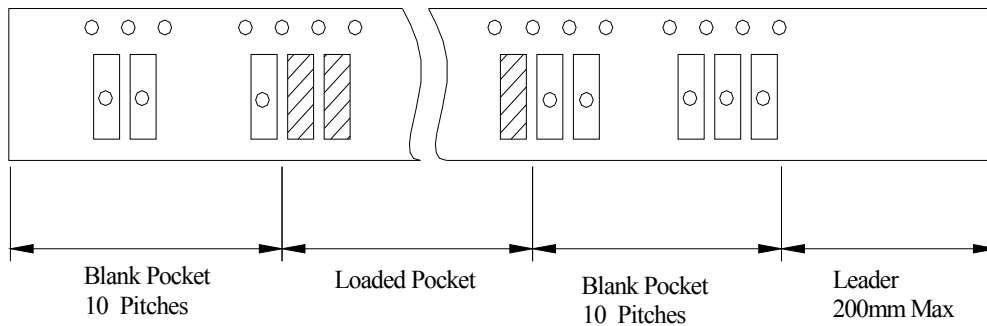

8.2.4 Test Condition Of Peeling Strength

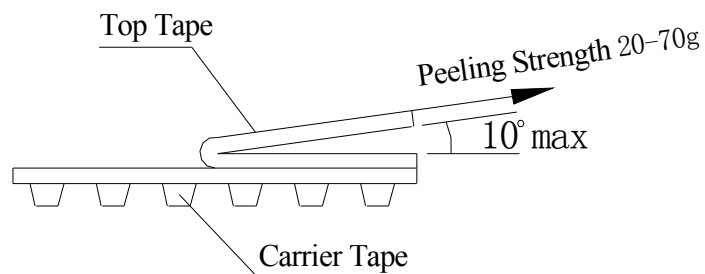

9. OTHER

9.1 Caution

9.1.1 Don't apply excess mechanical stress to the component and terminals at soldering. Do not use this product with bend.

9.1.2 Do not clean or wash the component for it is not hermetically sealed.

9.1.3 Do not use strong acidity flux, more than 0.2wt% chlorine content, in flow soldering.

9.1.4 Don't be close to fire.

9.1.5 This specification mentions the quality of the component as a single unit. Please insure the component is thoroughly evaluated in your application circuit

9.1.6 Expire date (Shelf life) of the products is six months after delivery under the conditions of a sealed and an unopened package. Please use the products within six months after delivery. If you store the products for a long time (more than six months), use carefully because the products may be degraded in the solderability or rusty. Please confirm solderability and characteristics for the products regularly.

9.1.7 Please contact us before using the product as automobile electronic component.

9.2 Notice

9.2.1 Please return one of this specification after your signature of acceptance.

9.2.2 When something gets doubtful with this specifications, we shall jointly work to get an agreement.